

PIL #23-004

RPL & MXL Drivelines Centre Bearing (with new double lip seal)

Date: December 2023

Subject: RPL & MXL Drivelines Centre Bearing (with new double lip seal)

Models: RPL 25; MXL 17/18

Product Information Letter #23-004

Dear Customer,

Cummins-Meritor Australia wants to advise of a product improvement and part number supersession for our Aftermarket Genuine centre bearings.

The product improvement is the inclusion of a new double lip seal that enhances the protection of the permanent lubricated driveshaft bearing (see figure 1).

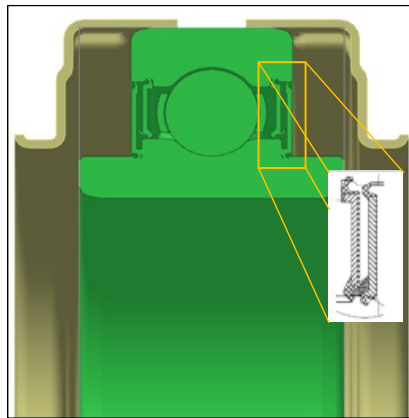

Figure 1. Sectioned view of the centre bearing (seal lip area enlarged)

The new range of centre bearings was first introduced, as a running change, in OEM production during 2022-2023. As we deplete the stock of the superseded parts, Cummins-Meritor Australia wants to communicate the new part numbers available as replacements.

Please see the list below to identify the new part numbers that you can order today:

- MXL18 Drivelines: CCB213 (OLD) → CCB216 (NEW)
- RPL25 Drivelines: HCB214 (OLD) → HCB217 (NEW)
- RPL35 Drivelines: MCB203 (OLD) → MCB206 (NEW)

There is no change in the service or installation procedures, fit or function of these centre bearings.

If you have any questions relating to the above, please contact a Cummins-Meritor Australia representative on +61 (03) 9300-5200.

**Issued by Product Engineering
Meritor HVSA Ltd**

Meritor Heavy Vehicle Systems
70 Berkshire Rd, Sunshine North, VIC 3020 Australia